

Since 1968

COMMAX
SmartHome & Security

User Manual

Building distributor CMD-101BU



www.commax.com

COMMAX Co.,Ltd.



- Thank you for purchasing COMMAX products.
- Please carefully read this User's Guide (in particular, precautions for safety) before using a product and follow instructions to use a product exactly.
- The company is not responsible for any safety accidents caused by abnormal operation of the product.



Contents

1. Introduction	2
2. Important Safeguard	3
3. Product Concept and Features	4
4. The wiring.....	6
5. Set the mode of building distributor.....	9
6. Specification.....	13



1. Introduction

Your unit is designed so it can be flush mounted on the or used. When flush mounted on the wall, the stand permits you to the unit for an gular of unit view. The model number is located on the bottom and record the serial number in the space provided below(available). Refer to these numbers whenever you call upon your COMMAX dealer regarding this product.

Model No.

Serial No.

To prevent fire or shock hazard, do not expose the unit to rain or moisture.



This symbol is intended to alert the use to the presence of uninsulated **"dangerous Voltage"** within the product' s enclose that may be of sufficient magnitude to constitute a risk of electric shock to persons.



This symbol is intended to alert the use to the presence of important operating and maintenance(servicing) instructions in the literature accompanying the appliance



caution

Risk of electric shock
do not open



CAUTION : To reduce the risk of electric shock, do not remove cover(or back) no user-serviceable part inside refer servicing to qualified service personnel



2. Important Safeguards

- ▲ **Damage Requiring Service** : This equipment from the power source and source and refer servicing to qualified service personnel under the following conditions
 - ① when the power is damaged.
 - ② if liquid has been spoiled or objects have fallen into the unit
 - ③ if the equipment has been exposed to rain or water.
 - ④ if the equipment has been dropped or otherwise damaged.
 - ⑤ when the equipment exhibits a distinct change in performance- this indicates a need for service.
- ▲ **Water and Moisture** : Do not use this product near water, for example, near a bath tub, wash bowl, kitchen sink, or laundry tub, in a wet basement, or near a swimming pool, and the like.
- ▲ **Accessories** : The product may fall, causing serious injury to a child or adult, and serious damage to the appliance. Any mounting of the manufacture's instructions, and should use a mounting accessory recommended by the manufacturer.
- ▲ **Object and Liquid Entry** : Never push objects of any kind into this product through openings as they may touch dangerous voltage points or short-out parts that could result in a fire or electric shock. Never spill liquid of any kind on the product.
- ▲ **Lightning** : For added protection for this product before a lightning storm, or when it is left unattached and unused for long periods of time, unplug it from the wall outlet and disconnect the other system. This will prevent damage to the product due to lightning and power-line surges. If you live in an area heavily prone to lightning storms, it is recommended that you invest in power-line, telephone-line, RF cable and actuator / polarization surge protectors to protect your appliance system from possible damage



3. Product Concept and Features

- CMD-101BU building distributor is used to interlock with floor distributor (CMD-404FU) and is developed for interlocking Modum systeme monitor with lobby and guard.
- CMD-101BU is limited to the following devices that can be connected to interlock
Lobby phone : Export-oriented type LOBBY (Gate View , Multi panel) Guard phone : Gate view guard phone (CDS-4GS) & Audio gate guard phone(CDS-2AG) Floor distributor: Modum distributor (CMD-404FU) (Required) Video phone : The video phone for 4-wire way Modum system(CMV-43A) Porter: AP-3SG(PORTER only) CCTV selector: CMD-104V, Adapter : RF-2A
- CMD-101BU Notes on wiring (It doesn't guarantee the quality of product for connection if you do not keep the following)
 - CMD-101BU building distributor can be installed up to six in one building.
 - It wire the CCTV selector, CMD-104VU, to "CMD-104VU(IN)" in the CMD-101BU.
 - Wire with "CMD-104VU(IN) OF NEXT CMD-101BU in "CMD-104VU(OUT)" of CMD-

101BU.

- It wire export-oriented UTP type Lobby (Gate View, Multi panel) to "LOBBY" in the CMD-101BU.
- It wire modum floor distributor (CMD-404FU)(Required) to "CMD-404FU" in the CMD-101BU.
- "GUARD IN" in the CMD-101BU
Guard phone : Gate View guard phone (CDS-4GS) and Audio Gate guard phone (CDS-2AG) Porter : It wire AP-3SG(PORTER only). The porter must wire with guard phone & use it.
- Wire with "GUARD IN" OF NEXT building distributor CMD-101BU in "GUARD OUT" of CMD-101BU.
- Floor distributor (CMD-404FU) by 40ea must be used within a maximum distance 300m from main entrance / CCTV .
- The distant from floor distributor (CMD-404FU) to Modum System video phone is within 30m.

- Separate power must be connected to CMD-101BU.(DC24V / 1A or higher)
- Each CMD-101BU must be installed to be supplied with the power (DC24V/1A) basically



4. The wiring

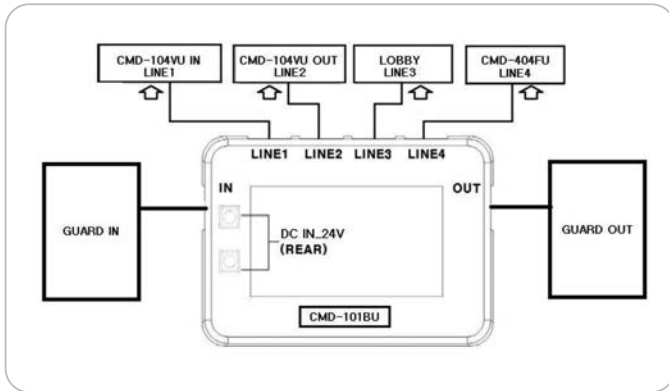

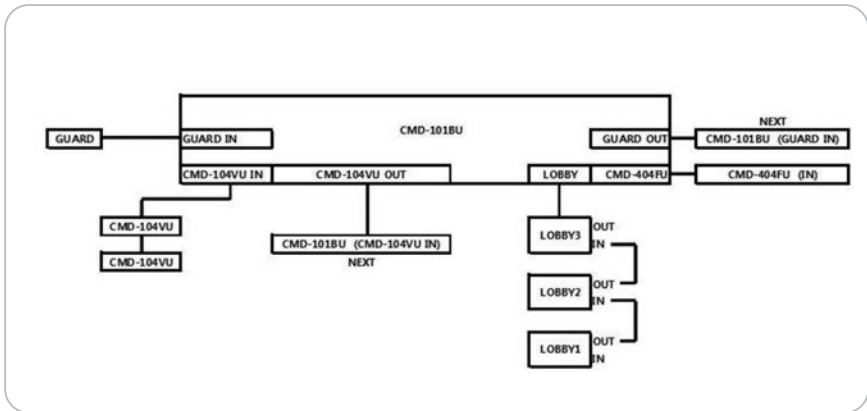

- Main entrance / CCTV → Building distributor(CMD-101BU) → CMD-404FU (1ST FLOOR) → CMD-404FU(2ND FLOOR) → ... → MODUM VIDEO PHONE

: UTP CABLE [CAT.5e] - MAX 300m

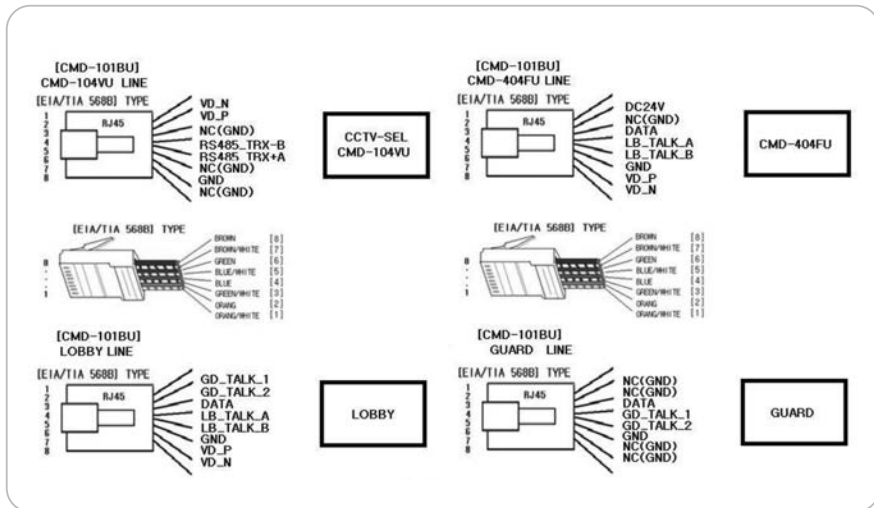



5. Set the mode of building distributor

- Using up the back of the product, DIP switch (8 channels) when you set the mode of building distributor.

- The function of each switch

NO. ① CCTV detection and master settings

A. If even one CCTV is installed through CCTV selector(CMD-104VU) , Switching on no1 can provide information to video phone from CCTV.

B. If it is shared in the unit of each of the two different building distributors with external CCTV, only one building distributor should be set as the master with switching number 1 on, the other should be placed by 1 switch off .

It is not possible to be set as the master at the same time two building distributors.

NO. ② Building number set

A. First, install Lobby Panel, set the building Number

B. When Modum system is installed in the first building with turning on NO2 switch, the building number of building distributor is set as common entrance number if you call monitor and guard station from lobby phone. After this, you should put back twice.

We use it when installing several sets of building distributor in one building.

NO. ③ If the building distributor is extended to several sets in a building, 1/2 number line has been set up when the Switch 3 is made on.

NO. ④ If the building distributor is extended to several sets in a building, 3/4 number line has been set up when the Switch 4 is made on.

NO. ⑤ If the building distributor is extended to several sets in a building, 5/6 number line has been set up when the Switch 5 is made on.

NO. ⑥ If the building distributor is extended to several sets in a building, 7/8 number line has been set up when the Switch 6 is made on.

NO. ⑦ If the building distributor is extended to several sets in a building, 9/10 number line has been set up when the Switch 7 is made on.

NO. ⑧ If the building distributor is extended to several sets in a building, 11/12 number line has been set up when the Switch 8 is made on.

Ex) Number 1 ~ 4 Line : Switch 3, 4 ON / Switch 5 ~ 8 OFF

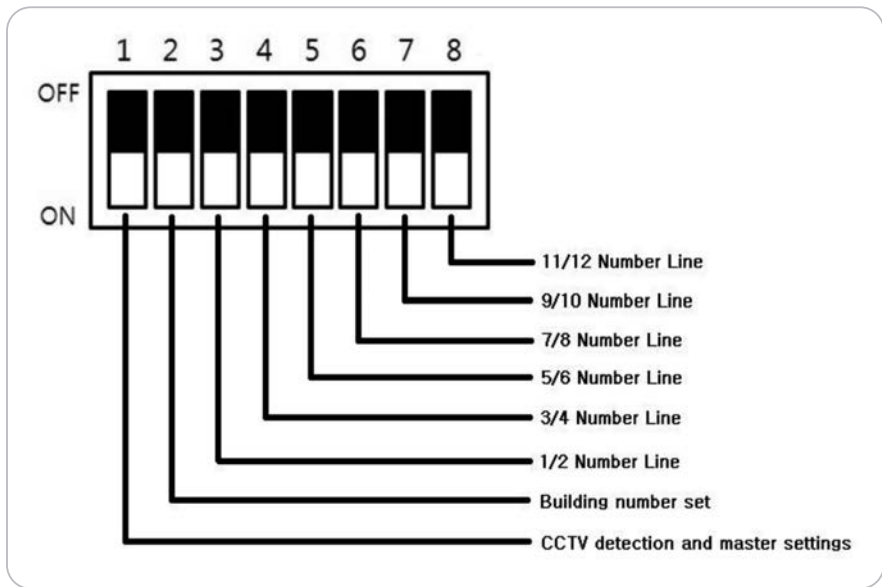



6. Specification

Spec	Model	CMD-101BU [Building distributor] (COMMAX MODUM DEVICE BUILDING DISTRIBUTOR)
Transmission way		Main entrance 8 lines (polarity), Modum system floor distributor(CMD-404FU) 6 lines(polarity) CCTV selector(CMD-104VU) 5 lines (polarity), Guard 4 lines (polarity) (RJ45 CAT5e Patch Cable)
Voltage		DC 24V / 1A (MAX)
Wiring Sequence		1. Modum system building distributor (CMD-101BU) → Floor distributor Wiring Sequence(CMD-404FU) IN (Input) 2. Main entrance/Guard/CMD-104VU → Modum system building distributor (CMD-101BU)
Wiring distance		From main entrance/CCTV to monitor is 300m. The distance from each floor distributor to monitor is limited by 30m. Maximum call distance from guard/porter to monitor is 1Km

COMMAX

COMMAX Co.,Ltd.

513-11, Sangdaewon-dong, Jungwon-gu, Seongnam-si, Gyeonggi-do, Korea
Int'l Business Dept. : Tel.; +82-31-7393-540~550 Fax.; +82-31-745-2133
Web site : www.commax.com

PM99101BU010

Printed In Korea / 2014.10.105